

MEFE
MITCHELL ENGINEERING
FOOD EQUIPMENT PTY LTD

Operating Manual



Wet Knife Sharpener

CAT 139 8101

Revision 5

General Safety Guidelines Before Using This Power Tool

- Always wear eye protection and respirator.
- Keep Bystanders out of the work area while operating the tool.
- Wheel nuts and eye shields must be properly adjusted and tightened.
- Always make sure wheels are properly mounted.
- Stand to the side of the sharpener during start up. Switch it on and let the sharpener operate at full speed for approximately one minute so that any undetected flaws or cracks will become apparent.
- Keep guards in place and working properly.
- Keep hands clear of grinding wheels.
- Never reach behind or beneath grinding wheels.
- Disconnect power before changing grinding wheels or servicing. The grinding wheels continue to rotate after the tool is switched off. Always allow wheels to stop before adjusting or servicing. Do not forcibly stop grinding wheel.
- To avoid electric shock, DO NOT use in damp conditions or expose to rain.
- When fitting a new grinding wheel, always check that the stated maximum RPM meets or exceeds the RPM stated on the sharpener, also check the wheel for damage, such as flaws or cracks, if the wheel appears satisfactory, fit it to the machine.
- When a new grinding wheel has been fitted, allow one minute of operation before use to check the wheel for flaws.
- Only use accessories that are recommended by the manufacturer of your model.
- DO NOT attempt to cut anything using the grinding wheel.
- Grounded tools must be plugged into an outlet that has been properly installed and grounded in accordance with all local codes and standards. Never remove the grounding prong from the plug or modify it in any way.
- Do not use adapter plugs, if in doubt as to whether the outlet is properly grounded, consult a qualified electrician.
- Do not use the tool when tired or under the influence of drugs, alcohol or medication.
- Do not wear loose clothing, gloves or jewellery; tie up long hair and button all long sleeve shirts.
- Ensure the power switch is off prior to plugging in the tool.
- Do not over tighten spindle nuts.
- Spacing between tool rest and wheels should be set to 1/8" or less; hold work piece firmly against tool rest.
- Service on these tools should only be performed by an authorized, qualified technician.

WARNING: Failure to follow these rules may result in serious personal injury!

Additional Specific Safety Rules

1. DO NOT operate this machine until it is completely assembled and installed according to the instructions. A machine incorrectly assembled can cause serious injury.
2. OBTAIN ADVICE from your supervisor, instructor, or another qualified person if you are not thoroughly familiar with the operation of this machine. Knowledge is safety.
3. FOLLOW ALL WIRING CODES and recommended electrical connections to prevent shock or electrocution.
4. Failure to adhere to the following could result in fragments flying off the wheel at high speeds causing serious personal injury:
 - Always use the provided washer and nut to mount the grinding wheel on the sharpener shaft to prevent wheel damage or accidental separation.

- Use only wheels suitable for the speed of the machine
 - Use only wheels that have a bore exactly equal to the shaft of the machine. Never attempt to machine an under-sized wheel to fit the shaft.
 - Do not use a wheel that vibrates. Dress the grinding wheel, replace it, or replace the bearings of the shaft.
5. Do not over tighten wheel nut.
 6. Inspect wheels for cracks or fragments before starting the machine. Replaced damaged wheels immediately.
 7. Adjust eye shields close to the grinding wheel, and readjust as the wheel wears down. Flying sparks are dangerous and can cause fires or explosions.
 8. Always make sure eye shields are properly in place, adjusted and secured.
 9. ADJUST TOOL RESTS close to grinding wheel (1/8" separation or less). Tighten the tool rest securely to prevent shifting positions and re-adjust as the wheel wears down. The work piece can be drawn into the wheel, causing damage to the work piece and/or serious injury.
 10. Make sure the machine is securely placed on a bench or stand before starting motor.
 11. Stand to one side before turning the machine on.
 12. Never grind on a cold wheel, run for a minute before use, a cold wheel has the tendency to chip.
 13. Never start the machine with a piece of work against the grinding wheel, the work piece can be drawn into the wheel, causing damage to the machine and/or serious injury.
 14. Clean the machine thoroughly when processing different types of work pieces (wood, steel or aluminium) combining wood and metal dust can create an explosion or fire hazard, Do not grind or polish magnesium. Fire will result.
 15. Never grind near flammable gas or liquids. Sparks can create a fire or explosion.
 16. Avoid awkward operations and hand positions. A sudden slip could cause a hand to move into the grinding wheel.
 17. Keep arms, hands and fingers away from the wheel. The abrasive surfaces can cause serious injury.
 18. Always use the tool rest and hold work piece firmly with both hands when grinding.
 19. Dress the wheel on the face only, dressing the side of the wheel could cause it to become too thin for safe use.
 20. Grind a work piece using the face of the grinding wheel only.
 21. Never apply coolant directly to the grinding wheel, coolant can weaken the bonding strength of the grinding wheel and cause it to fail. Dip the work piece in water to cool it.
 22. Do not touch the ground portion of a work piece until it has cooled sufficiently. Grinding creates heat.
 23. Properly support long or wide work pieces.
 24. Never perform layout, assembly or set up work on the table/work area when the machine is running. A sudden slip could cause a hand to move into the wheel.
 25. Turn the machine off, disconnect the machine from power source and clean the table/work area before leaving the machine. Lock the switch in the OFF position to prevent unauthorized use.

Please note: To prevent overheating the best operating practice is to run the unit for no more than 15 minutes uninterrupted, following a 5 minute cool down before further use. The machine should be used with a duty cycle of 75%.

You can run the machine for a maximum of 3-4 hours continuously, however this does run the risk of overheating the motor and voiding your warranty. The copper wire can undertake 130°C, and the machine body can undertake 75°C.

WARNING: Read, understand and observe all instructions in this manual before using or operating the tool for which it is written and supplied. Ensure that anyone who is to use the tool has read and understood the instructions provided.

Parts List

No.	Description	Part No.	Qty
1	Horizontal mounts with knobs	-	2
2	Universal Support	-	1
3	Leather Stropping Wheel	CAT 139 04	1
4	Vertical mounts with knobs	-	2
5	On/off Switch	-	1
6	Honing Compound	CAT 139 8	1
7	Variable Angle Guide	CAT 139 9	1
8	Water reservoir	CAT 139 05	1
9	Grinding Wheel	CAT 139 02	1
10	Straight Edge Jig	-	1

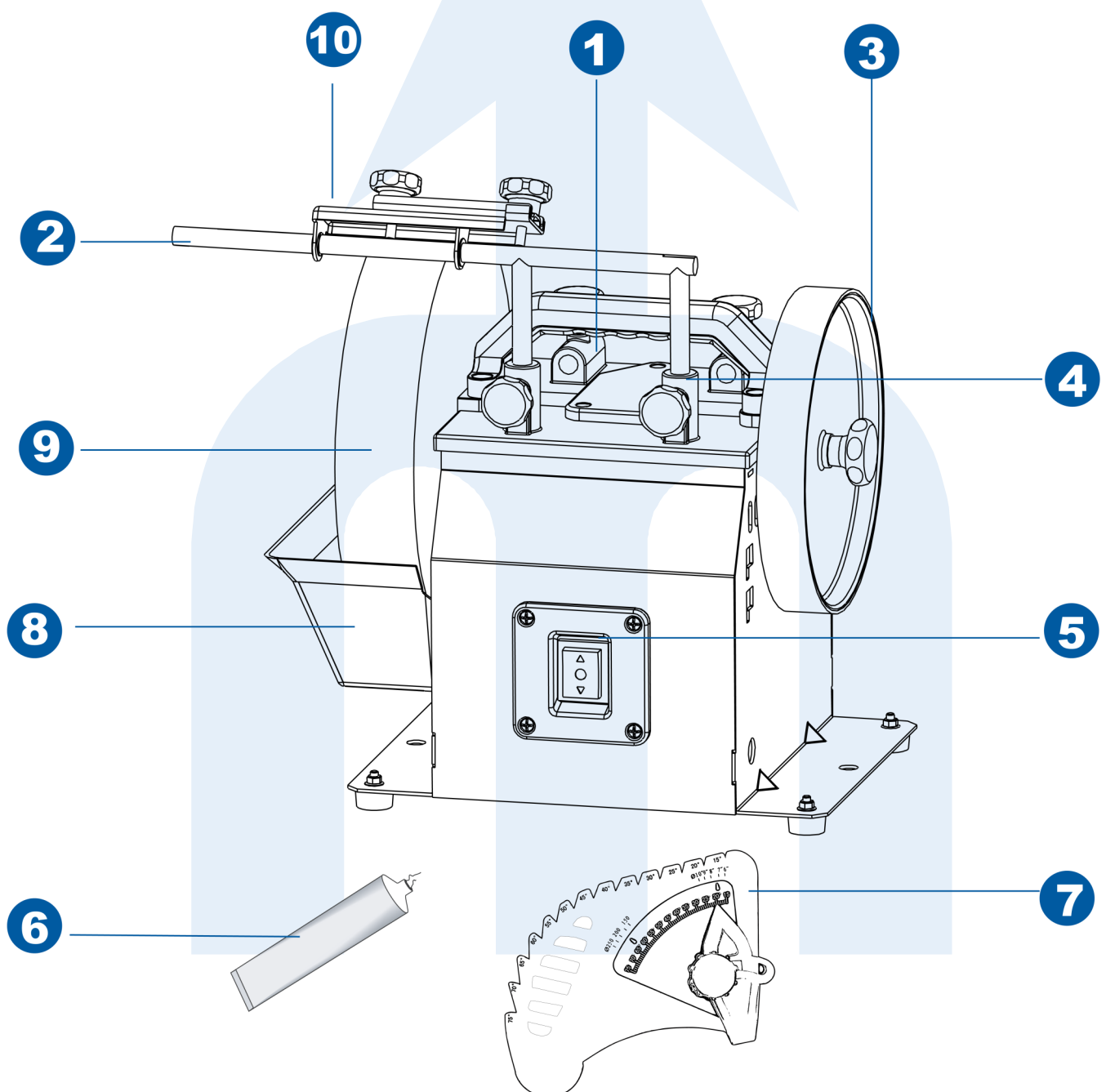

Package Contents

No.	Description	Qty
1	Sharpener	1
2	Universal Support	1
3	Straight Edge Jig	1
4	Wet Grinding Wheel	1
5	Water Reservoir	1
6	Bolt Flat Washer	1
7	Variable Angle Guide Jig	1
8	Honing Compound	1

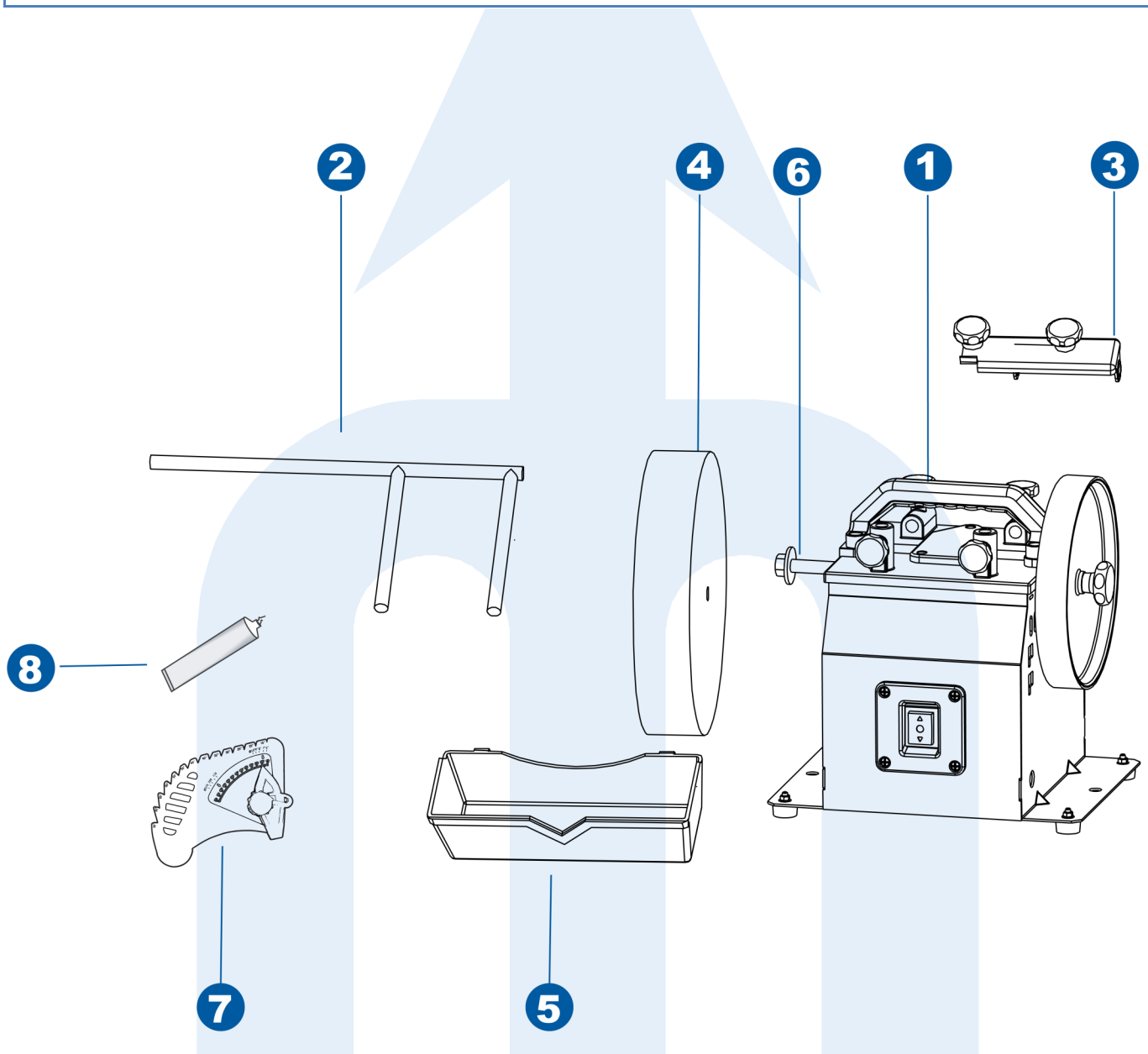

Placement

See figure 3 for the minimum working Clearances. Remember that the sharpener has no specific front or back and must be repositioned depending on the desired grinding/sharpening/honing action.

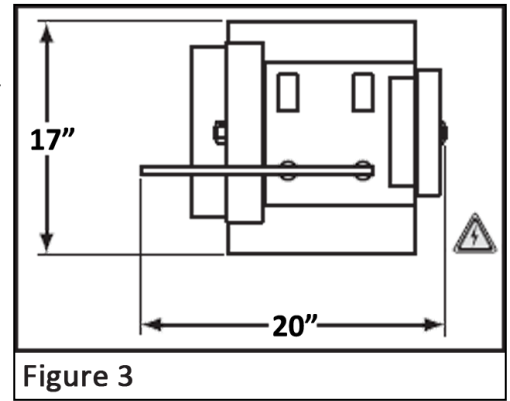

To avoid damage to the rubber drive wheel during shipping.

The motor drive shaft has been pulled away from the rubber wheel and held by Styrofoam. Before plugging in your machine. Carefully tilt machine on its side and carefully remove the Styrofoam that holds the motor.

To remove the motor shipping support

1. Make sure the machine is not connected to power.
2. Carefully place the machine on its back.
3. Hold the motor to prevent it swinging, remove the Styrofoam, then slowly release the motor.
4. Carefully return the motor to the upright position.

Note: Remove the Styrofoam holding the motor before use!

Caution: Failure to do this will put undue strain on the motor, resulting in potential damage to the machine components, and will void your warranty.

Maintenance

Grinding Wheels

The grinding wheels should be inspected before each use. Take care in storing grinding wheels to keep them free from potential damage from moisture, from being dropped or from having other items dropped on them.

Wheel Replacement

To replace the grinding or stropping wheel:

- DISCONNECT THE SHARPENER FROM POWER!
- Wait for wheel to stop then hold the wheel to stop it from turning and remove the nut holding the wheel on.
- Remove the outer washer and wheel.
- Install the new wheel, then replace the washer and nut.

Water Reservoir

Be sure to periodically empty, rinse and refill the reservoir with clean water depending on frequency of use. Failing to do so can lead to a build up of sediment on the wheel itself, reducing grinding performance.

Grinding Tips

- Always be sure the grinding wheel is wet before grinding by having the reservoir filled and in the proper location.
- Wear the proper protective clothing. Safety glasses/face shield and a dust mask should be worn at all times.
- Grasp the work piece firmly and properly support it on the universal support or grinding jig during operation. Maintain even pressure and control of the work piece when grinding.
- Concentrate on the task at hand. STOP grinding if other people are distracting you or your mind is on something else.

Positioning the Universal Support

- The wet sharpener is equipped with a universal support that serves as a tool rest and as an attachment point for the sharpener jig. It can be attached in two positions, allowing for grinding with or against the rotation direction of the grinding wheel.
- The tightening knobs on each attachment point allow the universal support to be adjusted and locked in position, depending on the specific task required.
- Working against the rotation removes large amounts of material quickly but does not yield precise results. Use this method for coarse tools such as axes.
- Working with the rotation yields much more precise results and removes less material. Use this method for finer tools, such as knives or carving tools.

Grinding Against Wheel Rotation

The sharpener additionally has been outfitted with an electrical power switch that permits the grinding wheel to rotate in the front and reverse directions.

- DISCONNECT SHARPENER FROM POWER!
- Position the machine with the ON/OFF switch facing you.
- Attach the universal support in the vertical mounts, as shown in Figure 4. Be sure it is securely positioned and will not move during grinding.
- Rest your work piece on the universal support with the sharpened edge pointing away from you. Grind your work piece in the indicated grinding area.

Grinding with Wheel Rotation

- DISCONNECT SHARPENER FROM POWER!
- Position the machine with ON/OFF switch facing away from you.
- Attach the universal support in the horizontal mounts as shown in Figure 5. Be sure it is securely positioned and will not move during grinding.
- Rest your work piece on the universal support with the sharpened edge pointing away from you. Grind your work piece in the indicated grinding area.

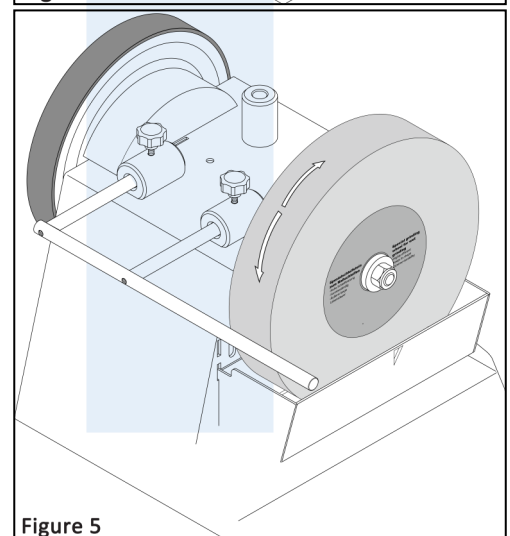
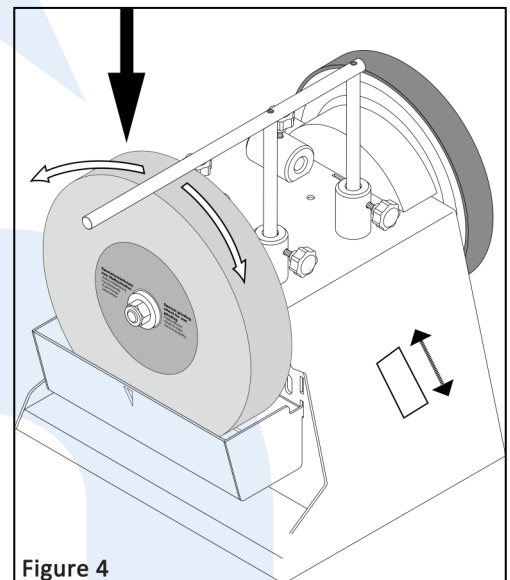

Straight Edge Jig

The Straight Edge jig provided with the wet sharpener is used for securing a variety of tools, and can be positioned to grind with and against the wheel rotation.

To mount the grinding jig:

- DISCONNECT SHARPENER FROM POWER!
- Slide the grinding jig onto the universal support, as illustrated in Figure 6.
- Insert the tool into the jig clamp, then use the angle guide, as described in the manual, to set the grinding angle.
- Once the grinding angle is set, tighten both lock knobs to secure the tool in place.

Water Reservoir

The wet sharpener is designed for wet grinding and should never be used without water. Before filling the water reservoir, identify the high and low reservoir mounting slots, as shown in Figure 7. These slots allow the reservoir to be raised during grinding and lowered when not in use.

The mounting tabs on the reservoir serve as hooks to attach to the reservoir mounting slots.

To fill and position the Water Reservoir

- Remove the reservoir and fill it with water to just below the V-shaped notch.
- Attach the reservoir to the sharpener.
- - if the sharpener is going to be used immediately, position the reservoir in the upper grinding position by attaching it in the upper slot (see Figure 8).
- -If the sharpener is not going to be used immediately, position the reservoir in the lower storage position by attaching it in the lower slot (see figure 8)

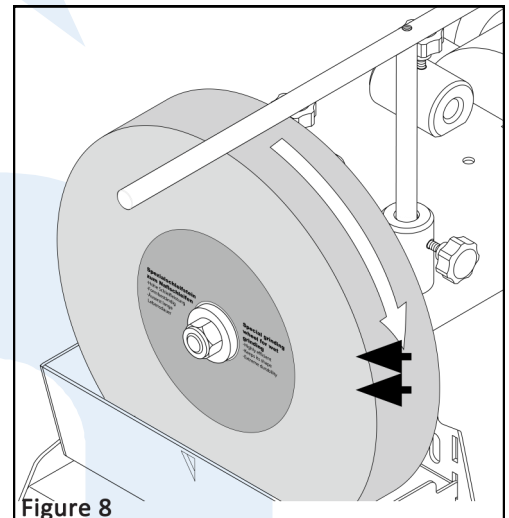
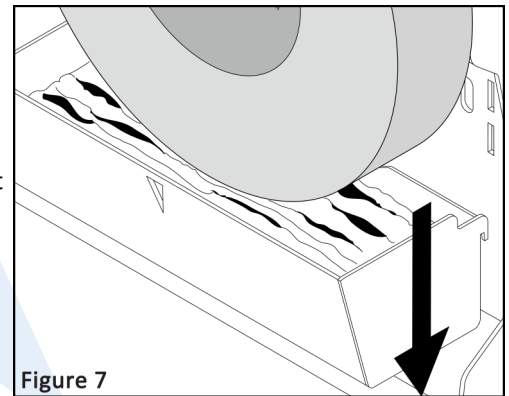
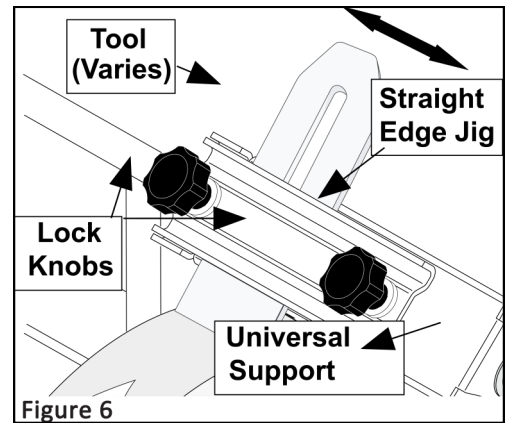

Note: Placing the reservoir in the lower storage position will reduce the likelihood damage to the wheel and potential hazards from being stored in water.

Caution: Always ensure to switch "OFF" when the sharpener is not in use. In the event of a power failure, blown fuse, or tripped circuit breaker, turn the switch "OFF" preventing accidental start-up when the power comes back on.

Tips for using the sharpener water reservoir

- Check the water level before every use and be sure the wheel is wet before you begin grinding. DO NOT use the sharpener without water.
- Leaving the grinding wheel stored in water will cause damage to the wheel and create potential hazards because the wheel will become unbalanced. Once any grinding process is complete, return the reservoir to the storage position to prevent prolonged water exposure to the wheel.
- Empty, rinse and refill reservoir regularly. This prevents metal and stone from accumulating in the reservoir.
- Place a magnet in the reservoir to catch and collect metal filings. This will help prevent excessive metal accumulation on the grinding wheel.

Angle Guide

The sharpener comes with an angle guide to help identify and maintain the cutting angle on a variety of tools.

To use the angle guide:

To mount the grinding jig:

- Locate the eight measuring notches on the angle finder.
- Find the angle notch that best fits the tool you wish to grind by placing the sharpened edge of the work piece into the notch.
- Adjust the positioning of the tool and the universal support height as necessary so that the sharpened edge of the tool is flat against both the grinding wheel and the angle edge on the angle guide.

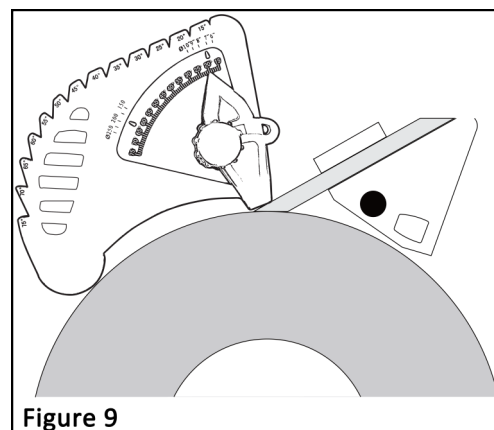

Figure 9

Wheel Dressing

Depending on the type of grinding you do, the grinding wheel may require periodic dressing.

A variety of dressing tools are available (not included) and can be used to restore the abrasive quality of the wheel surface and bring the wheel edge back to the right form. Refer to the instructions that accompany your dressing accessory for complete details on how to properly dress a wheel.

When grinding, metal objects become heated quickly. It is important to keep moving the object back and forth across the face of the grinding wheel and to cool the object frequently using a coolant tray.

Sharpening

The leather stropping wheel on the sharpener and the included abrasive stropping paste can be used to obtain a razor sharp edge on many tools. Before use, the stropping wheel must be properly prepared.

Note: A slight wobble of the stropping wheel when it is rotating is normal and does not affect the performance.

To prepare the stropping wheel:

- Evenly apply a light machine oil to the leather wheel. Use enough oil to provide a thorough coating, but not so much as to saturate the leather and resulting in dripping.
- Apply a thin coat of abrasive honing paste to the leather wheel using a wooden spreader or similar device (not included). Distribute the paste evenly by hand turning the wheel while spreading.
- Connect the machine to power, then turn the machine on and continue to distribute the paste, still using the wooden spreader. Move the spreader lightly in a circular motion across the wheel.
- Once the paste is evenly distributed, begin sharpening.
- These preparations will be sufficient for sharpening five to ten tools. If you notice a drop in sharpening performance or have sharpened more than ten tools, repeat above steps.

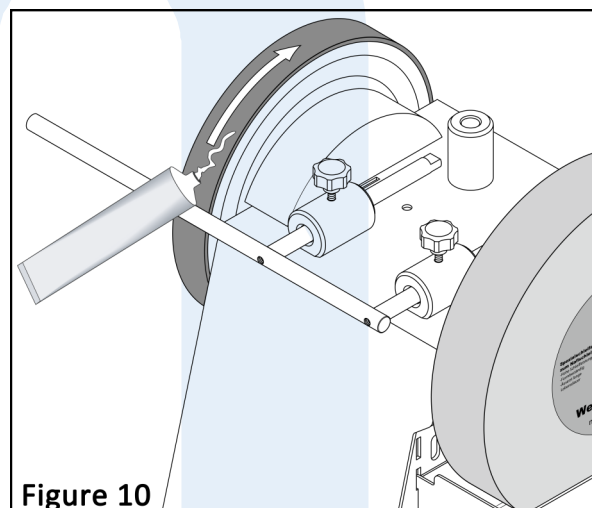
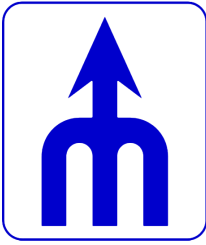

Figure 10



MEFE
MITCHELL ENGINEERING
FOOD EQUIPMENT PTY LTD

Sharpening Guide



Sharpening guide for Jigs

Compatible wheel diameter \varnothing 150mm - \varnothing 250mm

Revision 1

CAT 139 9

Included with CAT 139 8100, CAT 139 8101 & CAT 139 8102

Using the Grinding Angle Set-Up Jig

Use the Grinding Angle Set-Up Jig to set the blade at exactly the correct angle for sharpening.

1. Mount the blade in the Straight Edge Jig and place the support arm in the mount
Note: *The Grinding Angle Set-up Jig can be used in conjunction with other jigs in the MEFE range.*
2. Use the gauge on the outside of the Grinding Angle Set-Up Jig to measure the bevel angle of the blade.
3. Loosen the locking knob on the Grinding Angle Set-Up Jig and adjust the protractor so that the black arrows are aligned with the correct grindstone diameter marking
4. Then set the pointer to the required bevel angle on the blade (as measured in Step 2, above) and tighten the locking collar to lock in position
5. Thread the Straight Edge Jig onto the support arm so that the blade rests against the grindstone
6. Position the curved foot of the Grinding Angle Set-Up Jig on the grindstone and the flat section of the pointer on the blade to be sharpened
7. Adjust the height of the support arm until the flat section on Grinding Angle Set-Up Jig pointer lies perfectly flat on the blade

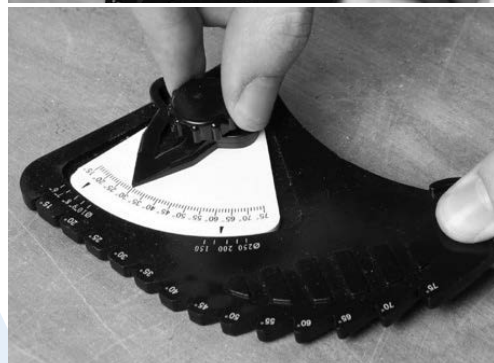

Using the Straight Edge Jig

Included with CAT 139 8100, CAT 139 8101 & CAT 139 8102

For use with the Support Arm and Grinding Angle Set-Up Jig to set the blade at exactly the correct angle for sharpening

1. Loosen the knobs on the Straight Edge Jig
2. Place the blade in the jig so that one edge of the blade is positioned against the end stops
3. Tighten the knobs to fasten the blade in position

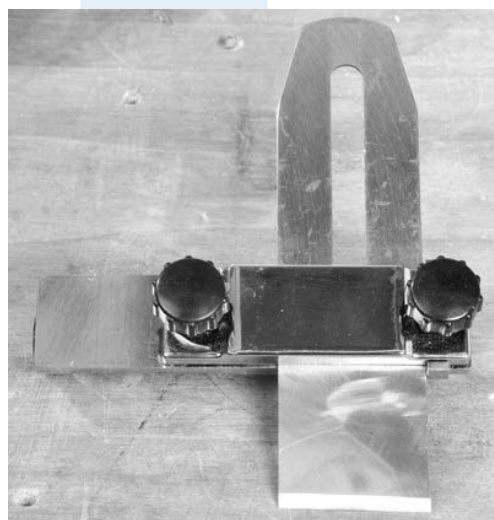

Using the Support Arm (Included with CAT 139 8100, CAT 139 8101 & CAT 139 8102)

The Support Arm can be attached for grinding with or against the direction of rotation of the grindstone



For grinding against the direction of rotation:

Place the Support Arm in the Vertical Mounts



For grinding and honing with the direction of rotation:

Place the Support Arm in the Horizontal Mounts

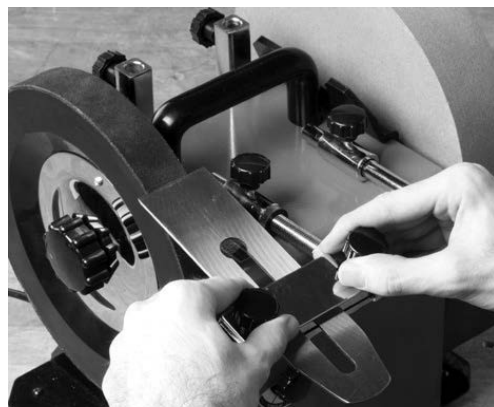

WARNING: Honing must ONLY be carried out WITH the direction of rotation.

- Working against the direction of rotation removes larger amounts of material more quickly than working with the direction of rotation
- Working with the direction of rotation can be used for very precise sharpening of a blade for finer tools and is used for honing
- Take your time and practise the set up with various types and sizes of blades so that you can achieve the correct sharpening angle and ensure the blade to be sharpened is square across the surface of the grindstone
- In general, for sharpening, position the support arm in the vertical mounts and sharpen against the direction of rotation
- NEVER place the support arm in the vertical mounts when using the leather honing wheel. Attempting to hone the blade against the direction of rotation will cause severe damage to the honing wheel

Long and Short Knife Jig

Included with CAT 139 8100 & CAT 139 010

1. Blade Clamp
2. Adjustable Jig Stop
3. Clamp Thickness Screw
4. Jig Tightening Knob
5. Jig Stop Adjustment Knob

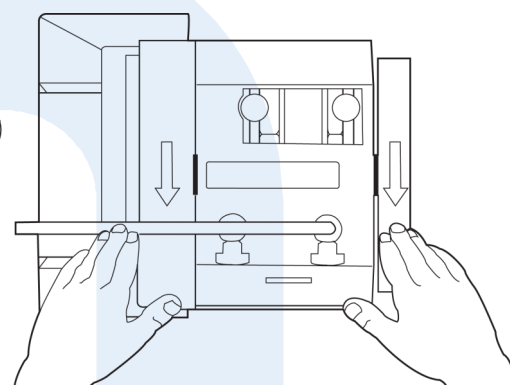
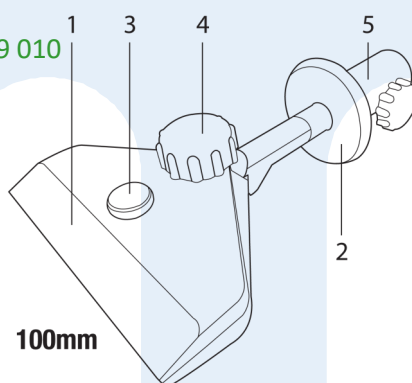

Grinding Direction: Towards the front

Using the Long or Short Knife Jig:

- The Blade Clamp (1) is designed for holding knives of any thickness, which is fully adjustable with the Clamp Thickness Screw (3)
- The Adjustable Jig Stop (2) can be moved into the desired position based on the knife's size by easily loosening Jig Stop Adjustment Knob (5), moving the Jig Stop then retightening the Jig Stop Adjustment Knob
- Lock the Long Knife Jig by tightening the Jig Tightening Knob (4)
- Use the Support Arm to rest the jig on and use the Adjustable Jig Stop to steadily control sharpening of the knife

Note: The long knife jig is especially designed for use with long and thin knives, such as filleting knives. Because the Long Knife Jig is wide, it provides ample support required for long, thin blades.

Scissors Jig

Restores sharp edges to blunt scissors and garden shears. Twin clamps for securing blades.

Included with CAT 139 8100 & CAT 139 010

1. Jig Support Plate
2. Scissor Clamp Holder
3. Scissor Clamp
4. Clamp Thickness Screw
5. Jig Tightening Knob

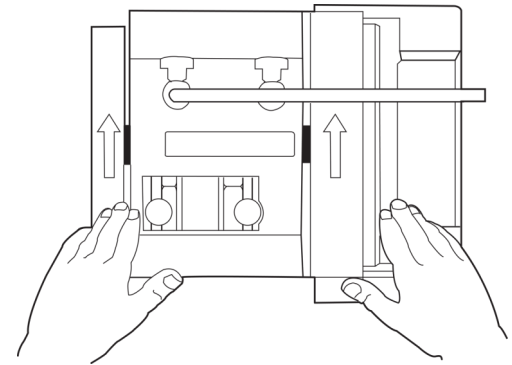
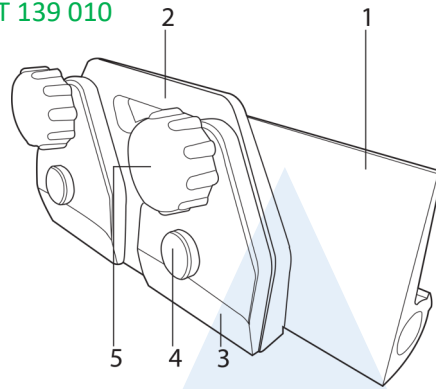

Using the Scissors Jig:

- The Scissor Clamp Holder (2) is fitted with 2 Scissor Clamps (3). Normally, only the Scissor Clamp on the right is required; however, for large scissors or shears the other clamp can also be used
- Adjust the Scissor Clamp/s to fit the scissor blade thickness. Loosen the Jig Tightening Knob (5) then the Clamp Thickness Screw (4). Insert the scissor blade and re-tighten
- The Jig Support Plate has a surface designed to allow the jig to move easily while sharpening

IMPORTANT: DO NOT use the Leather Honing Wheel to remove the burr from the scissor blade after using the Grindstone. To remove the burr, draw the scissor blade through the grain at the end of a piece of wood.

Note: Portable electric-planer blades (not tungsten carbide blades) are ground in the same way as scissor blades; however, honing using the Leather Honing Wheel is required.

Setting the bevel edge angle

- The scissors' bevel edge angle is set by adjusting the Jig Support Plate. Either repeat the existing angle or create a new bevel edge angle by using the Grinding Angle Set-Up Jig

The same bevel edge angle:

1. Slide the Jig Support Plate (1) onto the Support Arm and tighten
2. Use a black marker pen to colour the bevel edge of scissor blade; rest the jig on the Jig Support Plate with the scissors' bevel edge touching the grinding wheel; and, using your hand, turn the grinding wheel a quarter turn
3. Check the bevel edge to see what part of the black pen mark has been scratched off, then adjust the Jig Support Plate to correct the angle
4. Re-test the quarter-turn scratch and re-adjust the Jig Support Plate if required

A new bevel edge angle:

1. Slide the Jig Support Plate onto the Support Arm and tighten
2. Use the Grinding Angle Set-Up Jig to set-up the Scissor Jig at the new angle (see 'Using the Grinding Angle Set-Up Jig')



Axe Jig

Included with CAT 139 8100 & CAT 139 010

Using the Axe Jig:

The jig is designed so that the rotation of the stone presses the axe firmly into the jig. You only need to hold and guide the axe with your hands. This jig only works with the stone running towards the edge. If necessary, the honing wheel can be removed to allow clearance for the axe handle.

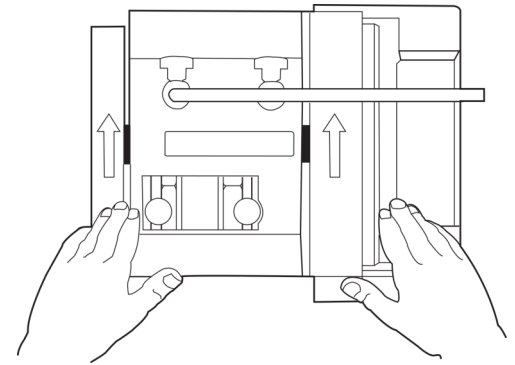

Grinding Direction: Towards the edge

1. Place the axe into the jig. Set the edge angle by adjusting the Universal Support. Either at the original angle or at a new angle using the Angle Guide Jig.
2. Press with your palm on the axe, close to the stone. The axe will automatically be pressed up against the stop in the jig and the grinding is most efficient.
3. Follow the shape of the edge (straight or curved) during grinding by raising or lowering the handle. Let the jig slide sideways on the Universal Support so that the stone wears evenly.

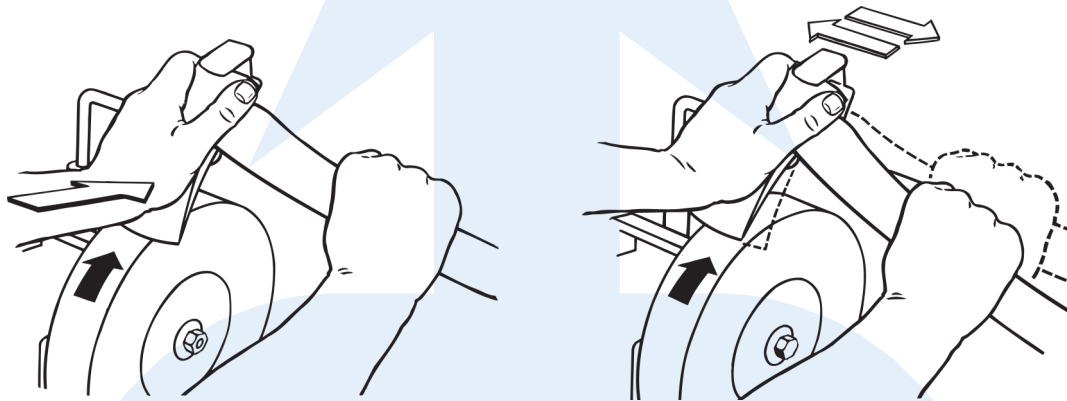

Edge angle

- The edge angle of a carpenter's axe or hatchet should be 25–30°, depending on the hardness of the wood. Grind the edge with a smaller bevel angle on the side towards the wood than on the other side. This longer bevel gives you a good support towards the wood. Also, as the axe works closer to the surface of the wood, the cutting will be more effective and easier to control.
- A felling axe and a hunting axe must have a larger edge angle, 30–40°, so that the edge is more durable. Round off the heels of the bevels and the axe cuts more easily. This is done by lowering the Universal Support and grinding in two steps.

Honing

Honing and polishing the bevels on the leather honing wheel makes the edge cut more easily and the sharpness will stay longer. Always hone away from the edge.



Machine and Pack Information

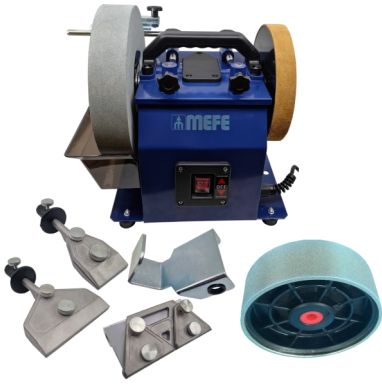

CAT 139 8100 - Knife Sharpener Bundle

Includes:

- 1 x CAT 139 8101 - Knife Sharpening Machine
- 1 x CAT 139 010 - Knife and Blade Jig Set
- 1 x CAT 139 02 10 - 200mm 1000 Grit Diamond Sharpening Wheel



CAT 139 8101 - Knife Sharpening Machine

Includes:

- 1 x Knife Sharpening Machine
- 1 x 250mm 220 Grit Grinding Wheel
- 1 x 200mm Leather Honing Wheel
- 1 x CAT 139 9 Angle Guide Jig
- 1 x Honing Paste
- 1 x Straight Edge Jig
- 1 x Universal Support Bar

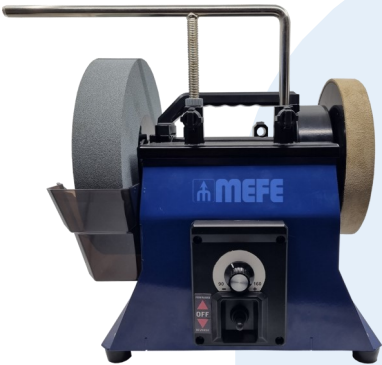

CAT 139 8102 - Variable Speed Knife Sharpening Machine

Includes:

- 1 x Variable Speed Knife Sharpening Machine
- 1 x 250mm 220 Grit Grinding Wheel
- 1 x 200mm Leather Honing Wheel
- 1 x CAT 139 9 Angle Guide Jig
- 1 x Honing Paste
- 1 x Straight Edge Jig
- 1 x Universal Support Bar

CAT 139 010 - Knife and Blade Jig Set

Includes:

- 1 x Short Knife Jig
- 1 x Long Knife Jig
- 1 x Scissors Jig
- 1 x Axe Jig



CAT 139 9 - Angle Guide

Includes:

- 1 x Variable Angle Guide Jig

