

**MEFE**  
MITCHELL ENGINEERING  
FOOD EQUIPMENT PTY LTD

# Operating Manual



## Vegetable Cutter

CAT 361 VC12

Revision 2

# Contents

<b>1. General Warning</b> .....	3
<b>2. Product Design and Features</b> .....	3-4
<b>2.1 Safety Features</b> .....	3
<b>2.2 Product Features</b> .....	4
<b>2.3 Product Design</b> .....	4
<b>3. Technical Data</b> .....	4-5
<b>4. Inspection</b> .....	5
<b>5. Installation</b> .....	5-6
<b>5.1 Circuit Diagram</b> .....	6
<b>5.2 Operation Instructions</b> .....	6
<b>6. Operation</b> .....	6-7
<b>6.1 Food Feeding</b> .....	6
<b>6.2 Sharpener</b> .....	7
<b>7. Cleaning</b> .....	7
<b>7.1 Cleaning Steps</b> .....	7
<b>7.2 Daily Cleaning</b> .....	7
<b>8. Maintenance &amp; Closing Down</b> .....	8
<b>8.1 Belt</b> .....	8
<b>8.2 Feet</b> .....	8
<b>8.3 Power Cable</b> .....	8
<b>8.4 Blades</b> .....	8
<b>8.5 Label</b> .....	8
<b>8.6 Closing down machine</b> .....	8

## 1. General Warning

- This machine should be operated by professionals familiar with the safety measures.
- If the operator is a beginner, they should be trained before operating.
- Please cut off the power before cleaning or performing maintenance on the machine.
- If the protection measures are to be taken off because of cleaning and maintenance, the risks must be evaluated carefully.
- Attention must be highly focused for cleaning and maintenance.
- Protecting the machines power cables is necessary. Damaged power cable may can results in an electric shock.
- Please contact us if malfunctions occur or the machine needs to be adjusted or maintained. Operators are not recommended to repair damages.
- The machine should not be used to cut bone, frozen meat or fish and non-food substances.
- When the machine is working, please do not put your hands into it.
- Under the following circumstances, the producer will not take charge:
  1. The machine is operated by an unprofessional.
  2. Components of the machine have been replaced with parts produced by different factories.
  3. The operator has not obeyed rules.
  4. The machine has not been maintained properly.

## 2. Product Design and Features

### 2.1 Safety Features

- The cover plays an important role in protection. The cover can be moved away if arm lock is up.
- Micro mechanical device—The machine will stop working if the arm lock is up or the cover is not on properly.
- Relay—If the power cuts off, the machine should be restarted.
- Motor—The motor contains PTC thermal protection: When the machine works for a long time, the motor temperature can exceed a set temperature and the machine will automatically turn off. In the event of overheating remove the plug and restart the machine after 10 minutes.
- Even though this machine is equipped with electrical and mechanical safety features (for working, maintenance and cleaning), some risks cannot be avoided that may happen while feeding food and performing maintenance (hands may be hurt by blades) so please always take extreme caution.

## 2.2 Features of Product

The machine focuses on processing (cutting, breaking, and mixing) food including; vegetables, meat and bread and we promise:

1. The machine will remain safe while working, cleaning and maintenance.
2. The choice in materials is according to the highest sanitary standard. To ensure easy cleaning and assembly, the components in contact with food are all streamline designed.
3. All components are stable and firm.
4. Belt driving makes the least amount of noise.
5. The machine is portable.

This machine is made from 304 Stainless Steel. All components contacting food confirm the requests of sanitary standards, and prevent components from eroding of acid, salt and oxidation. The blades are made from 4Cr13stainless steel, the sharpness and hardness ensure the functions of cutting, breaking and mixing. **After use blades should be cleaned and dried (using cloth) and oil should be used to prevent rusting of the blades.** The mixing container is made of Stainless Steel, with a heat transferring bottom, and handles for portability.

## 2.3 Product Design

Figure 1—The Structure of Food Cutting Machine

1. Container
2. Cover
3. Arm Lock
4. Main Body
5. Power Cable
6. Feet
7. Button Board
8. Knob for Speed

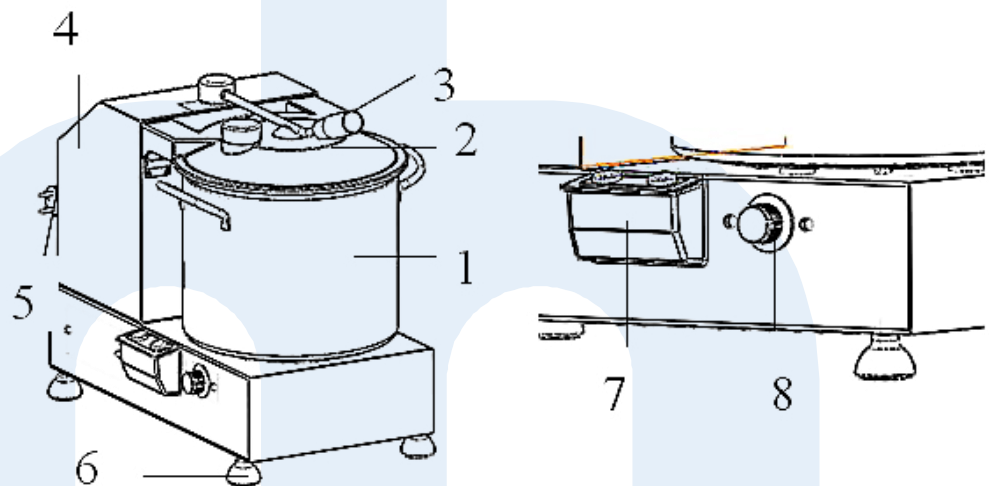

## 3. Technical Data

Model	A (mm)	B (mm)	C (mm)	Efficient Volume	Bowl Volume	Rotating speed (rpm)	Motor Power	Voltage (V)	Net Weight (kg)
CAT 361 VC12	523	316.5	489	5.6L	12L	980-2470	2000W	230/110	21.75

### 3. Technical Data Continued

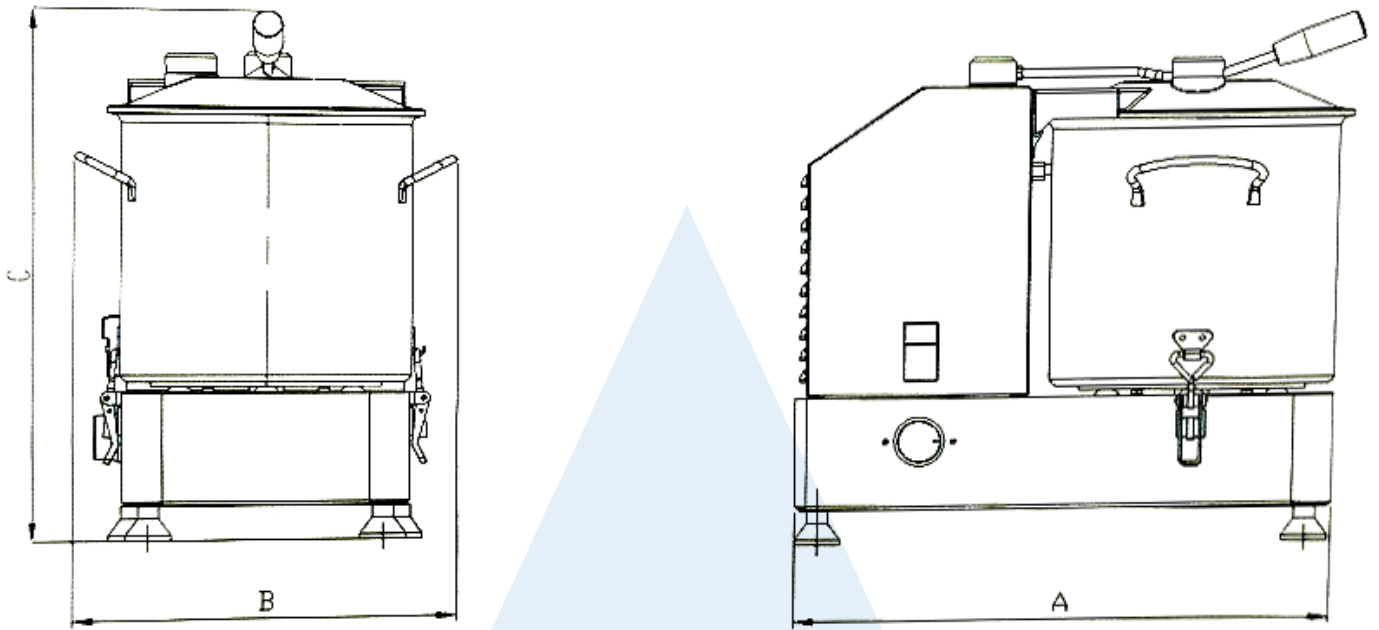

### 4. Inspection:

The package of the Vegetable cutter includes:

1. Good-quality cartons
2. Machine
3. Instruction Manual

If the cartons are found fine, please unpack it and check if the machine and parts can be located. If cartons are found impacted or damaged, please contact the carrier to inform them and submit detailed damage records.

**Do not put upside down!** Make sure the cartons are vertical with the floor, and keep it parallel with the floor while moving.

Package unit (includes cartons, pads, plastic bags and plastic foams) must be dumped in places according to local regulations.

### 5. Installation:

The machine should be located on a working table with a suitable size, the table must be dry, stable and horizontal. Besides this, the temperature of the room should be controlled between +5°C and +35°C to ensure the machine functions normally.

Before connecting, please check the power! The machine should be connected with current same as requested by nameplate.

## 5.1 Circuit Diagram

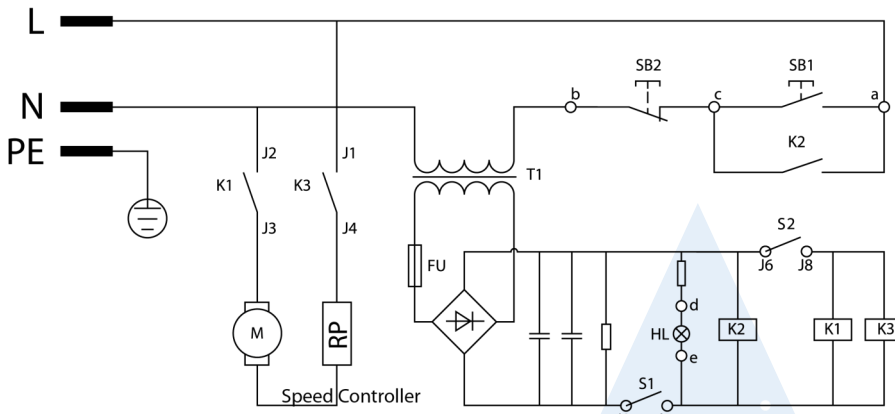

S.N.	Code	Name
1	M	Motor
2	SB1/LT1	Start Button "on"
3	SB1 / SB 2	Stop Button "Off"
4	SQ1~2	Microswitch
5	K1 / K3	Relay
6	K2	Relay
7		Speed Controller
8	T1	Potential Transformer
9	S1-2	Position Switch

## 5.2 Operation Instructions

Inspection for normal functions:

1. Press button "ON" and "OFF"
2. When the cover is moved away, check whether the machine stops working
3. Check if the knob for controlling speed works. Rotating speed is controlled by rotating the knob.

## 6. Operation

Attention: Knob for controlling speed is equipped on the food cutting machine.

### 6.1 Food Feeding:

Attention: food is to be fed only when the machine is stopped. The knob for controlling speed should be at "LOW" position.

#### Procedures:

1. Turn the loading arm anticlockwise to remove cover
2. Pay attention to the two blades while feeding into the container. Food should be cut into small blocks before feeding if it is big in size. **WARNING: The food in the container is not allowed to be more than 2/3 of the total volume. But it is suggested that food is above the blades. If there is not enough food, the machine may vibrate while running.**
3. In case of accidents, the operator should pay attention to their own position. The operator's body should be vertical with the working table. It is not allowed to press on the machine or prevent it from moving.

**Do not get close to the machine, and avoid touching the machine directly.**

4. Put cover into initial position, then turn the loading arm till locked.
5. Press the start -up button
6. Machine cannot stay on a low setting for long periods of time
7. While mixing if extra food should be added via the whole in the cover if needed
8. When the machine is finished, turn the speed controlling knob down and press "OFF" to stop the machine.



**Attention: the machine cannot be kept on for more than 3 minutes at a time. normal The cutting time depends on the size of food. The cutting time for food not included in the following chart can be according to request of the users.**

Item	Pork	Peanuts	Beans	Peppers	Leek	Celery
Cutting Time	18s	30s	60s	15s	40s	30s

## 6.2 Sharpener:

WARNING: Please sharpen the blades by the following procedures if the blades are not sharp enough to cut food.

1. Turn the loading arm to remove cover
2. Move away the fixing axis of rotating blades
3. Use the sharpener to sharpen the blades along the blades edge

## 7. Cleaning:

1. The machine should be cleaned at least one time every day . If necessary, the machine should be cleaned more frequently.
2. Any parts that directly touch food must be cleaned.
3. Water or high pressure spraying cannot be used directly on the machine to clean. Brushes and other tools which may damage the surface cannot be used for cleaning.
4. Blades should be cleaned and dried using a cloth after use, oil can also be used to prevent rusting.

The following procedures should be done before cleaning:

1. Cut off power
2. Turn speed adjusting to "LOW" setting.

### 7.1 Cleaning Steps:

Clean the cover, rotating blades axis and container:

Rotate the loading arm, remove the cover, and the blade fixing axis and container can be lifted easily. Then use water and neutralized detergent to clean the above mentioned parts. Attention: gloves should be worn for protection while operating.

### 7.2 Daily Cleaning

**Attention: power should be cut off**

Clean the machine body with neutralized detergent and a wet cloth. To dry the machine a dry cloth should be used.

## 8. Maintenance:

The following procedures should be done before any kind of maintenance:

1. Cut off the power
2. Turn the knob for controlling speed to "LOW" setting.

### 8.1 Belt:

Belt does not need to be adjusted. Normally the belt should be changed every nine months.

### 8.2 Feet:

After a period of time the feet will become damaged and inflexible. This may influence the stability of the machine, and must be replaced.

### 8.3 Power Cable:

Power cable should be checked regularly. If it is damaged, please change it.

### 8.4 Blades:

Check whether the width of the blades is less than 5mm, if so they must be replaced.

### 8.5 Label:

If the label is damaged, please change it.

## 9. Dumping of Equipment:

When the machine is to be dumped for any reason, make sure it cannot be used any more, then cut off the power. Contact the professional technical centre to disassemble the machine, and pay attention to the different type of material (details please refer back to features).