

Sensor Tap - Classic Curve Neck

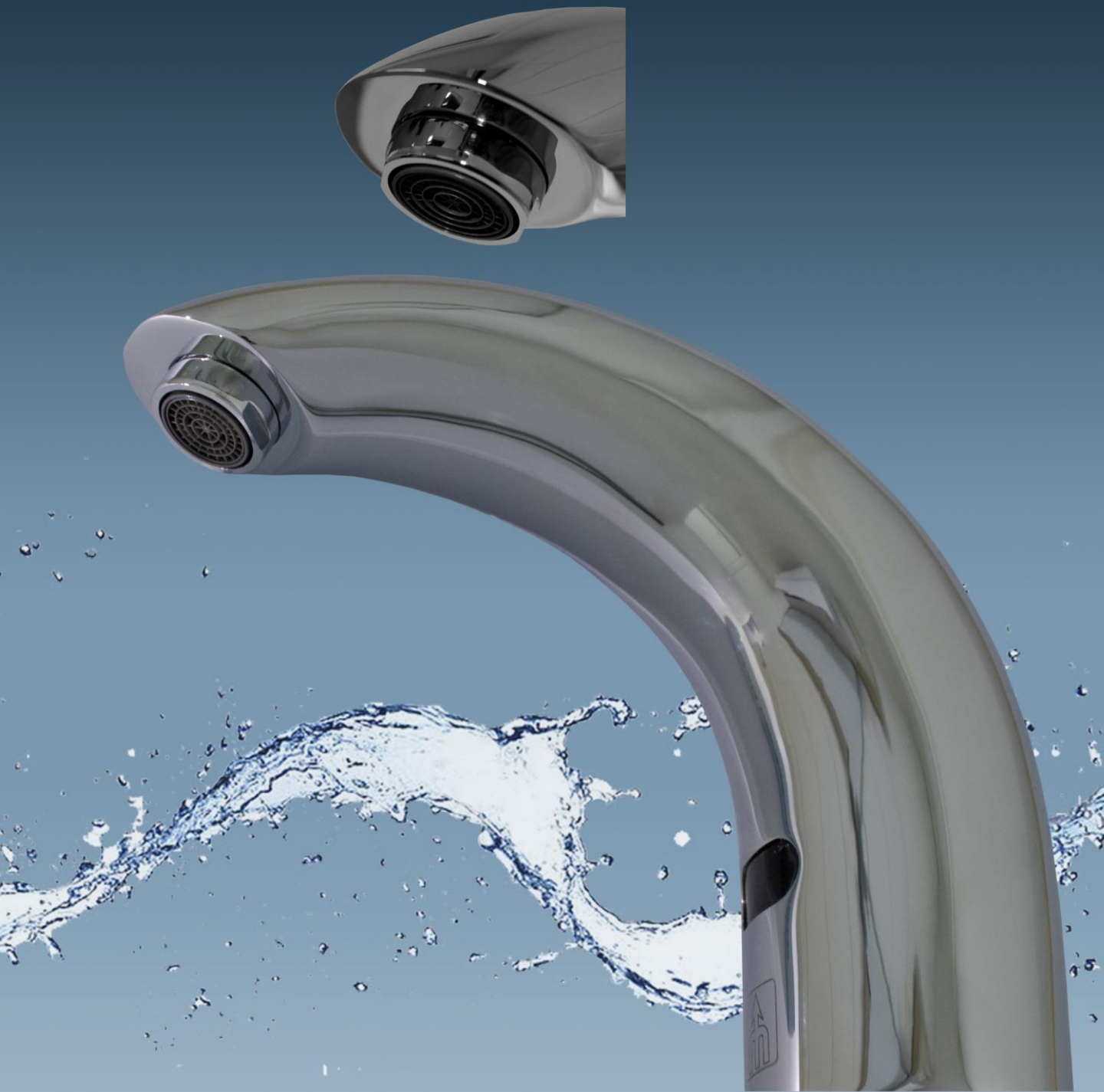

In accordance with AS/NZS 6400

Licence No. 1718

Mitchell Engineering Food
Equipment Pty Ltd



CAT 67911

Classic Curve Neck - Chrome Plated Deck Mounted

Features

Up to 70% water saved
Hygienic with zero cross contamination
Touch free and accessible activation
"Plug and play" digital infrared sensor technology
Sensing range automatically adjusts to your environment
Easy installation and supplied with everything required, replaces existing 1/2" connections
No electrical wiring required, 4 x AA batteries or 240V transformer



Includes

Curve spout with fitted sensor
Solenoid box (fitted solenoid valve and battery housing, batteries not supplied)
Optional 240V transformer
Braided hose
Instruction manual

Specifications

Deck Mounted
Chrome Plated
Standard 1/2" Connection
5 - 22cm Sensing Range
Water Pressure: 0.07-0.7Mpa

Available Finishes

-  CAT 67911 - Chrome Plated
-  CAT 67911B - Matte Black

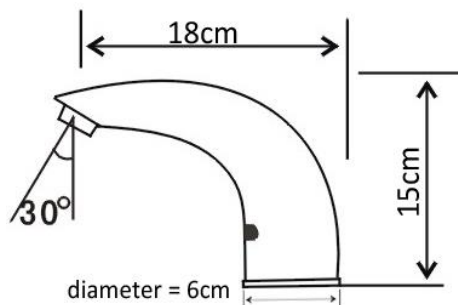

Dimensions

Curve Neck Spout - 15cm high
Tap: 15 x 18 x 6cm, 1.2kg
Boxed: 28 x 22 x 9cm, 2.1kg

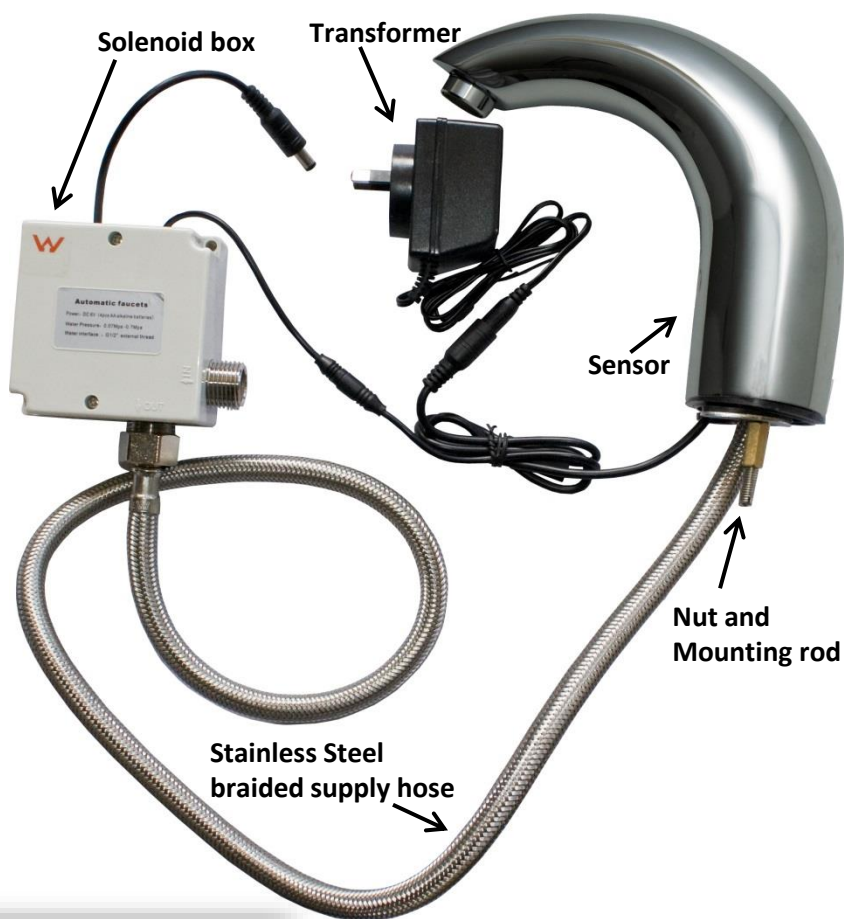

MEFE Sensor Taps are WaterMark certified and have been awarded 6 Stars, the highest WELS water efficiency rating. This signifies that our taps are eco-friendly and of the highest quality being AUS and NZ certified. Our range is DDA compliant when installed in accordance with AS 1428.1 2009.