

MEFE
MITCHELL ENGINEERING
FOOD EQUIPMENT PTY LTD

Sharpening Guide



Sharpening guide for Jigs

Compatible wheel diameter \varnothing 150mm - \varnothing 250mm

Revision 1

CAT 139 9

Included with CAT 139 8100, CAT 139 8101 & CAT 139 8102

Using the Grinding Angle Set-Up Jig

Use the Grinding Angle Set-Up Jig to set the blade at exactly the correct angle for sharpening.

1. Mount the blade in the Straight Edge Jig and place the support arm in the mount
Note: *The Grinding Angle Set-up Jig can be used in conjunction with other jigs in the MEFE range.*
2. Use the gauge on the outside of the Grinding Angle Set-Up Jig to measure the bevel angle of the blade.
3. Loosen the locking knob on the Grinding Angle Set-Up Jig and adjust the protractor so that the black arrows are aligned with the correct grindstone diameter marking
4. Then set the pointer to the required bevel angle on the blade (as measured in Step 2, above) and tighten the locking collar to lock in position
5. Thread the Straight Edge Jig onto the support arm so that the blade rests against the grindstone
6. Position the curved foot of the Grinding Angle Set-Up Jig on the grindstone and the flat section of the pointer on the blade to be sharpened
7. Adjust the height of the support arm until the flat section on Grinding Angle Set-Up Jig pointer lies perfectly flat on the blade

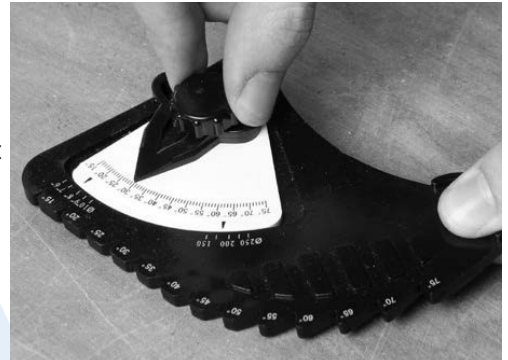

Using the Straight Edge Jig

Included with CAT 139 8100, CAT 139 8101 & CAT 139 8102

For use with the Support Arm and Grinding Angle Set-Up Jig to set the blade at exactly the correct angle for sharpening

1. Loosen the knobs on the Straight Edge Jig
2. Place the blade in the jig so that one edge of the blade is positioned against the end stops
3. Tighten the knobs to fasten the blade in position

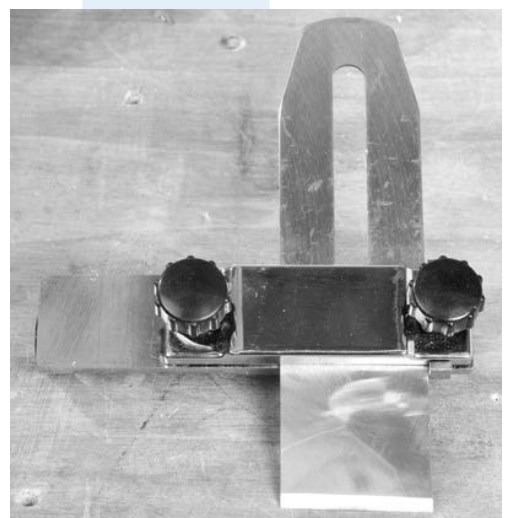

Using the Support Arm (Included with CAT 139 8100, CAT 139 8101 & CAT 139 8102)

The Support Arm can be attached for grinding with or against the direction of rotation of the grindstone



For grinding against the direction of rotation:

Place the Support Arm in the Vertical Mounts 

For grinding and honing with the direction of rotation:

Place the Support Arm in the Horizontal Mounts 



WARNING: Honing must ONLY be carried out WITH the direction of rotation.

- Working against the direction of rotation removes larger amounts of material more quickly than working with the direction of rotation
- Working with the direction of rotation can be used for very precise sharpening of a blade for finer tools and is used for honing
- Take your time and practise the set up with various types and sizes of blades so that you can achieve the correct sharpening angle and ensure the blade to be sharpened is square across the surface of the grindstone
- In general, for sharpening, position the support arm in the vertical mounts and sharpen against the direction of rotation
- NEVER place the support arm in the vertical mounts when using the leather honing wheel. Attempting to hone the blade against the direction of rotation will cause severe damage to the honing wheel

Long and Short Knife Jig

Included with CAT 139 8100 & CAT 139 010

1. Blade Clamp
2. Adjustable Jig Stop
3. Clamp Thickness Screw
4. Jig Tightening Knob
5. Jig Stop Adjustment Knob

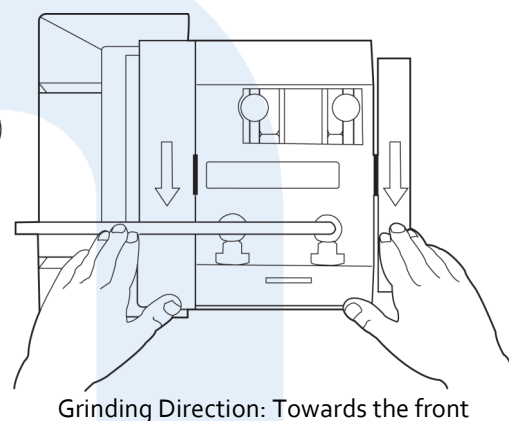
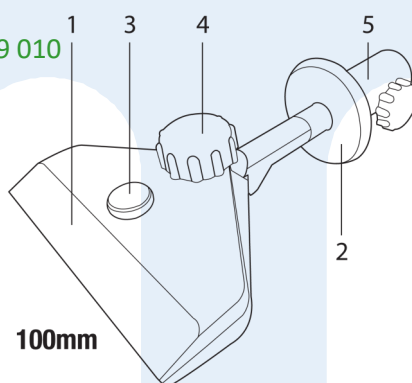

Using the Long or Short Knife Jig:

- The Blade Clamp (1) is designed for holding knives of any thickness, which is fully adjustable with the Clamp Thickness Screw (3)
- The Adjustable Jig Stop (2) can be moved into the desired position based on the knife's size by easily loosening Jig Stop Adjustment Knob (5), moving the Jig Stop then retightening the Jig Stop Adjustment Knob
- Lock the Long Knife Jig by tightening the Jig Tightening Knob (4)
- Use the Support Arm to rest the jig on and use the Adjustable Jig Stop to steadily control sharpening of the knife

Note: The long knife jig is especially designed for use with long and thin knives, such as filleting knives. Because the Long Knife Jig is wide, it provides ample support required for long, thin blades.

Scissors Jig

Restores sharp edges to blunt scissors and garden shears. Twin clamps for securing blades.

Included with CAT 139 8100 & CAT 139 010

1. Jig Support Plate
2. Scissor Clamp Holder
3. Scissor Clamp
4. Clamp Thickness Screw
5. Jig Tightening Knob

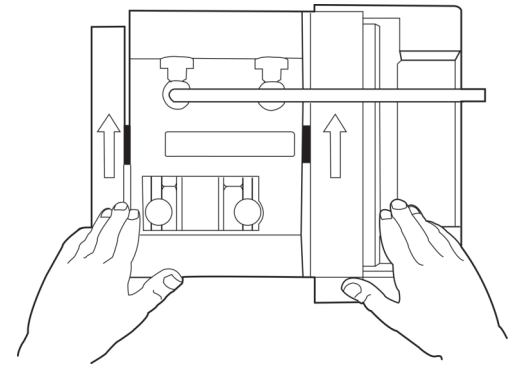
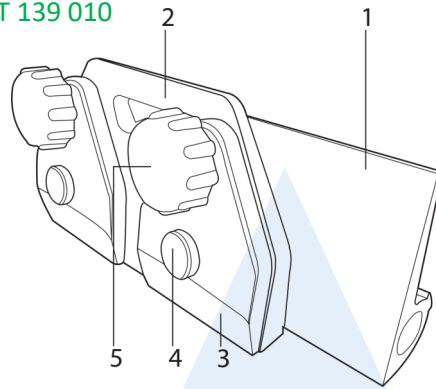

Using the Scissors Jig:

- The Scissor Clamp Holder (2) is fitted with 2 Scissor Clamps (3). Normally, only the Scissor Clamp on the right is required; however, for large scissors or shears the other clamp can also be used
- Adjust the Scissor Clamp/s to fit the scissor blade thickness. Loosen the Jig Tightening Knob (5) then the Clamp Thickness Screw (4). Insert the scissor blade and re-tighten
- The Jig Support Plate has a surface designed to allow the jig to move easily while sharpening

IMPORTANT: DO NOT use the Leather Honing Wheel to remove the burr from the scissor blade after using the Grindstone. To remove the burr, draw the scissor blade through the grain at the end of a piece of wood.

Note: Portable electric-planer blades (not tungsten carbide blades) are ground in the same way as scissor blades; however, honing using the Leather Honing Wheel is required.

Setting the bevel edge angle

- The scissors' bevel edge angle is set by adjusting the Jig Support Plate. Either repeat the existing angle or create a new bevel edge angle by using the Grinding Angle Set-Up Jig

The same bevel edge angle:

1. Slide the Jig Support Plate (1) onto the Support Arm and tighten
2. Use a black marker pen to colour the bevel edge of scissor blade; rest the jig on the Jig Support Plate with the scissors' bevel edge touching the grinding wheel; and, using your hand, turn the grinding wheel a quarter turn
3. Check the bevel edge to see what part of the black pen mark has been scratched off, then adjust the Jig Support Plate to correct the angle
4. Re-test the quarter-turn scratch and re-adjust the Jig Support Plate if required

A new bevel edge angle:

1. Slide the Jig Support Plate onto the Support Arm and tighten
2. Use the Grinding Angle Set-Up Jig to set-up the Scissor Jig at the new angle (see 'Using the Grinding Angle Set-Up Jig')



Axe Jig

Included with CAT 139 8100 & CAT 139 010

Using the Axe Jig:

The jig is designed so that the rotation of the stone presses the axe firmly into the jig. You only need to hold and guide the axe with your hands. This jig only works with the stone running towards the edge. If necessary, the honing wheel can be removed to allow clearance for the axe handle.

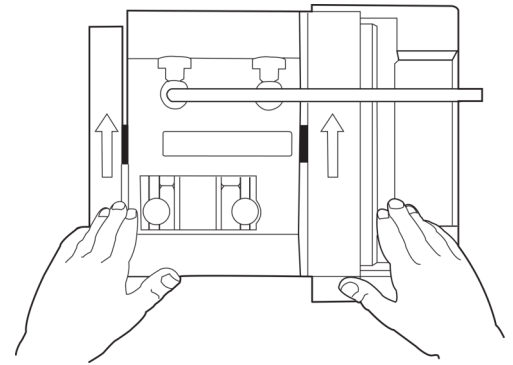

Grinding Direction: Towards the edge

1. Place the axe into the jig. Set the edge angle by adjusting the Universal Support. Either at the original angle or at a new angle using the Angle Guide Jig.
2. Press with your palm on the axe, close to the stone. The axe will automatically be pressed up against the stop in the jig and the grinding is most efficient.
3. Follow the shape of the edge (straight or curved) during grinding by raising or lowering the handle. Let the jig slide sideways on the Universal Support so that the stone wears evenly.

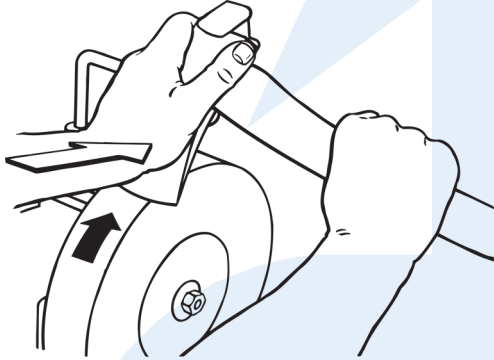

Edge angle

- The edge angle of a carpenter's axe or hatchet should be 25–30°, depending on the hardness of the wood. Grind the edge with a smaller bevel angle on the side towards the wood than on the other side. This longer bevel gives you a good support towards the wood. Also, as the axe works closer to the surface of the wood, the cutting will be more effective and easier to control.
- A felling axe and a hunting axe must have a larger edge angle, 30–40°, so that the edge is more durable. Round off the heels of the bevels and the axe cuts more easily. This is done by lowering the Universal Support and grinding in two steps.

Honing

Honing and polishing the bevels on the leather honing wheel makes the edge cut more easily and the sharpness will stay longer. Always hone away from the edge.



Machine and Pack Information

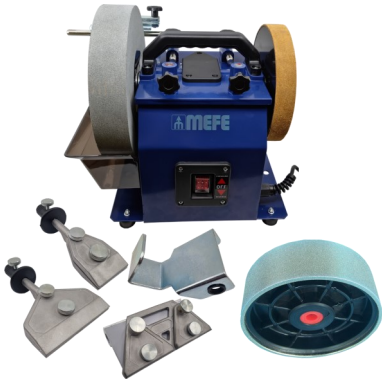

CAT 139 8100 - Knife Sharpener Bundle

Includes:

- 1 x CAT 139 8101 - Knife Sharpening Machine
- 1 x CAT 139 010 - Knife and Blade Jig Set
- 1 x CAT 139 02 10 - 200mm 1000 Grit Diamond Sharpening Wheel



CAT 139 8101 - Knife Sharpening Machine

Includes:

- 1 x Knife Sharpening Machine
- 1 x 250mm 220 Grit Grinding Wheel
- 1 x 200mm Leather Honing Wheel
- 1 x CAT 139 9 Angle Guide Jig
- 1 x Honing Paste
- 1 x Straight Edge Jig
- 1 x Universal Support Bar

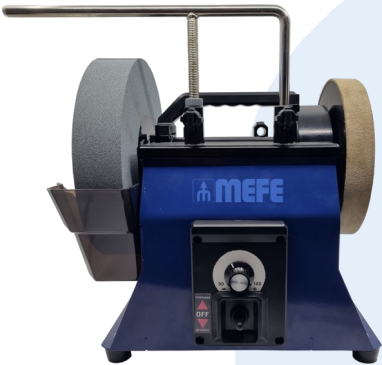

CAT 139 8102 - Variable Speed Knife Sharpening Machine

Includes:

- 1 x Variable Speed Knife Sharpening Machine
- 1 x 250mm 220 Grit Grinding Wheel
- 1 x 200mm Leather Honing Wheel
- 1 x CAT 139 9 Angle Guide Jig
- 1 x Honing Paste
- 1 x Straight Edge Jig
- 1 x Universal Support Bar

CAT 139 010 - Knife and Blade Jig Set

Includes:

- 1 x Short Knife Jig
- 1 x Long Knife Jig
- 1 x Scissors Jig
- 1 x Axe Jig



CAT 139 9 - Angle Guide

Includes:

- 1 x Variable Angle Guide Jig

